

# Standard Analog Current Output Modules

## Features

- Provides a single channel of optically- isolated digital-to-current conversion
- The "T" module is transformer isolated, which eliminates any ground loop problems
- Modules plug into any Standard Classic analog I/O rack and are secured by a captive screw

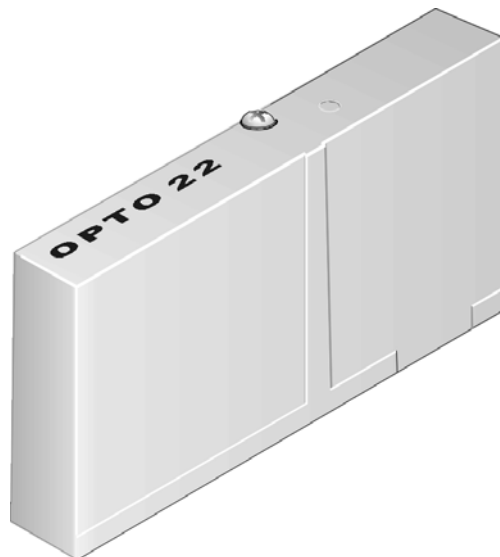

Modules plug into any Standard Classic analog I/O rack and are secured by a captive screw.

## Description

The current output modules provide a single channel of optically- isolated digital-to-current conversion. The "T" module is transformer isolated, which eliminates any ground loop problems. The DA3 and DA8 modules are UL approved.

## Specifications

|                      | DA3  | DA3T   | DA8  |
|----------------------|--|--|--|
| Output Current       | 4-20 mA  | 4-20 mA  | 4-20 mA  |
| Minimal Current Draw | 1.6 mA   | 1.6 mA   | 1.6 mA   |
| Accuracy             | 16 $\mu$ A   | 16 $\mu$ A   | 20 $\mu$ A   |
| Power Requirements   | 20 mA at +15 (+/- 0.25) VDC<br>10 mA at -15 (+/- 0.25) VDC<br>24 mA at 5 VDC | 22 mA at +15 (+/- 0.25) VDC<br>22 mA at -15 (+/- 0.25) VDC<br>24 mA at 5 VDC | 20 mA at +15 (+/- 0.25) VDC<br>10 mA at -15 (+/- 0.25) VDC<br>24 mA at 5 VDC |
| Agency Approvals     | UL, CE, RoHS, DFARS  | CE, RoHS, DFARS  | UL, CE, RoHS, DFARS  |

|  |                                   |
|--|-----------------------------------|
| Response Time  | Full scale step change in 3 ms    |
| Resolution   | 12 bits                           |
| Isolation<br>Input-to-Output<br>Input-to-Analog Supply (T Modules)   | 4,000 Vrms<br>4,000 Vrms          |
| Temperature<br>Operating<br>Storage  | 0 °C to 70 °C<br>- 25 °C to 85 °C |
| <b>DA3T:</b> All of the lower A terminals on the mounting rack are tied together. These provide a convenient tie point for shared loop source return. To use the DA3T with a common loop supply, connect any one lower A terminal to the shared loop source "-", then jumper upper A to lower A for each DA3T. |                                   |

## Part Numbers

| Part | Description             |
|------|-------------------------|
| DA3  | 4-20 MA Output          |
| DA3T | 4-20 MA Output Isolated |
| DA8  | 0-20 MA Output          |

# Standard Analog Current Output Modules

## Connections

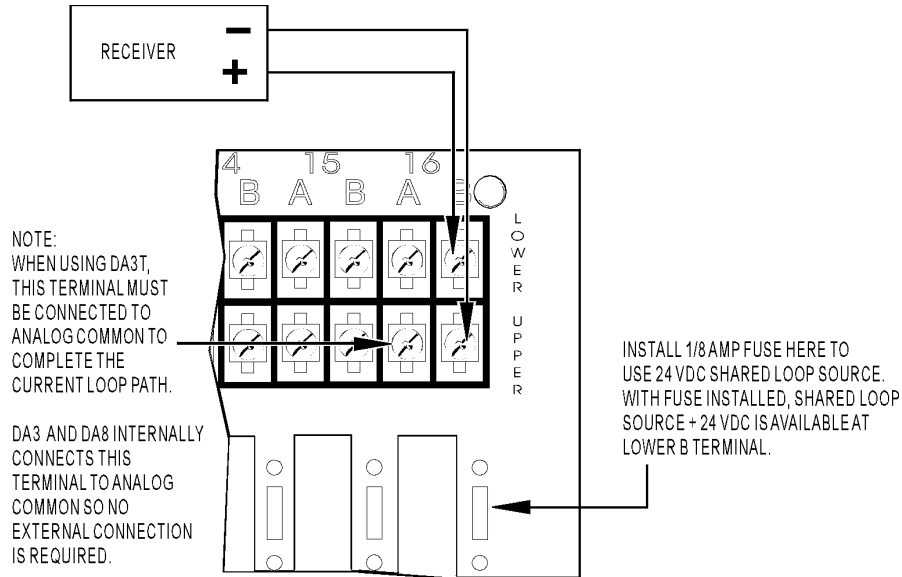

# Standard Analog Current Output Modules

## Connections (continued)

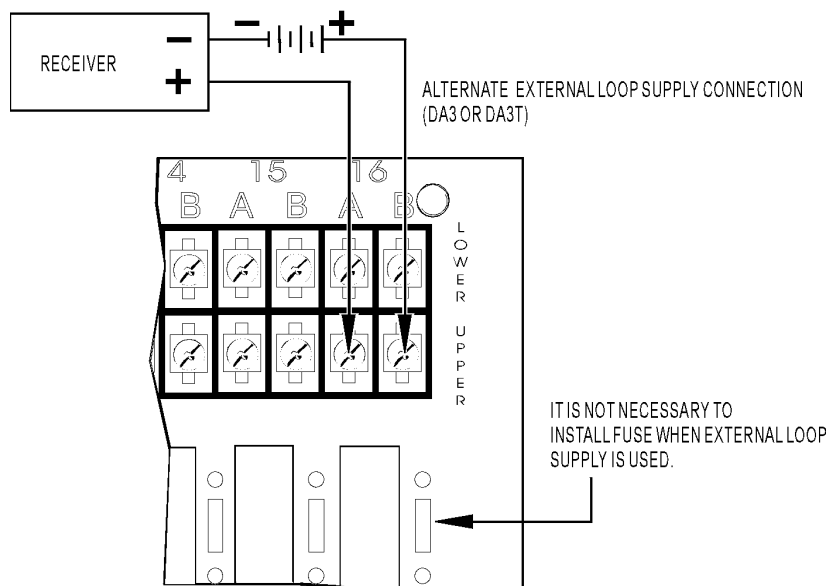
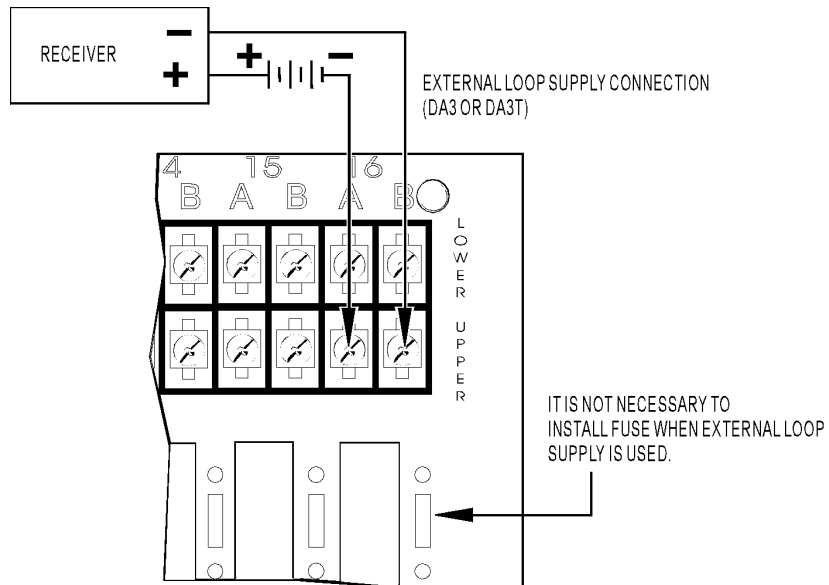

# Standard Analog Current Output Modules

## Schematics

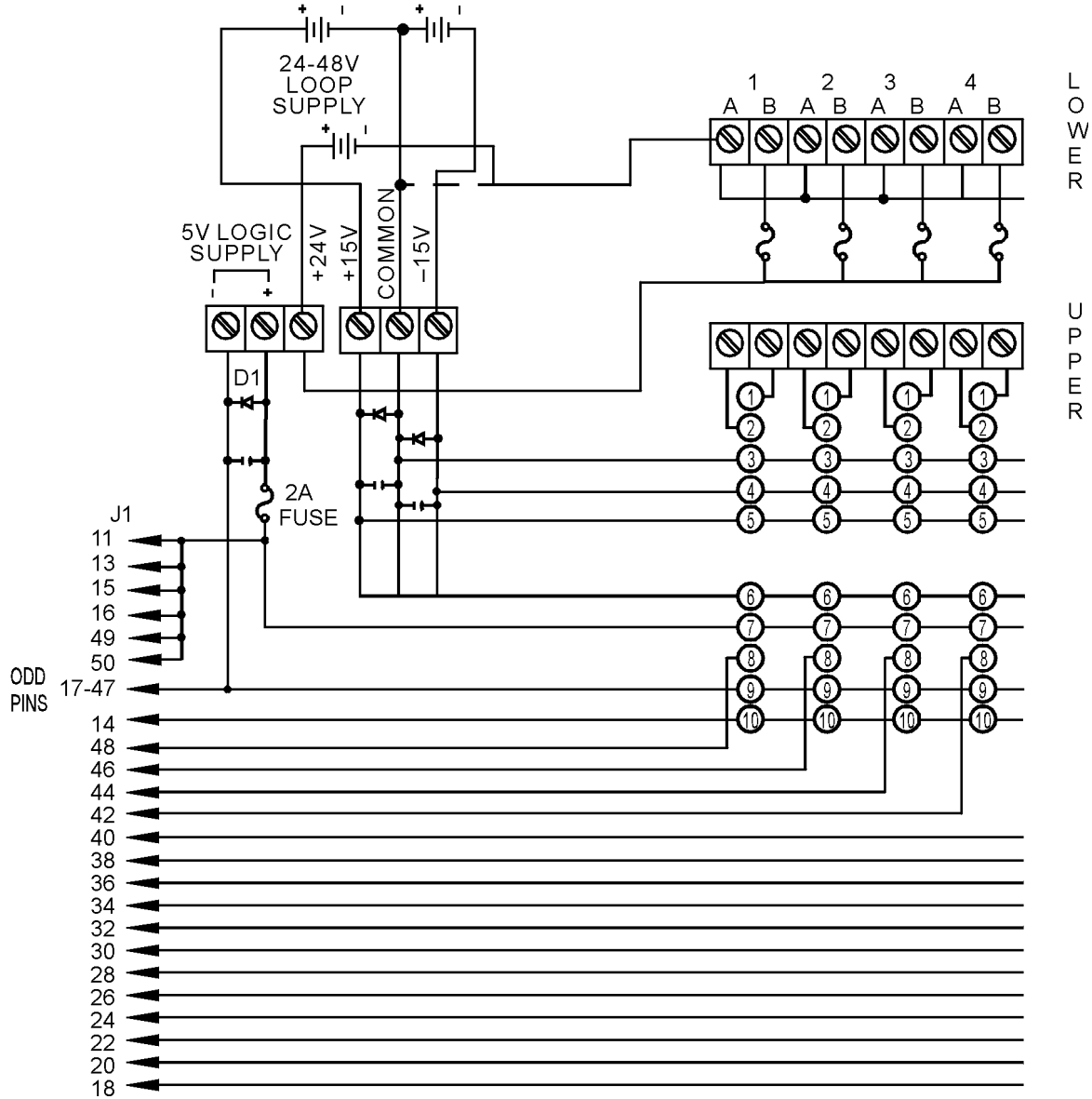

# More About Opto 22

## Products

Opto 22 develops and manufactures reliable, flexible, easy-to-use hardware and software products for industrial automation, energy management, remote monitoring, and data acquisition applications.

### groov

groov puts your system on your mobile device. With zero programming, you can build mobile operator interfaces to monitor and control systems from Allen-Bradley, Siemens, Schneider Electric, Modicon, and many more. Web-based groov puts mobile-ready gadgets at your fingertips. Tag them from your existing tag database, and they automatically scale for use on any device with a modern web browser. See [groov.com](http://groov.com) for more information and your free trial.

### SNAP PAC System

Designed to simplify the typically complex process of selecting and applying an automation system, the SNAP PAC System consists of four integrated components:

- SNAP PAC controllers
- PAC Project™ Software Suite
- SNAP PAC brains
- SNAP I/O™

### SNAP PAC Controllers

Programmable automation controllers (PACs) are multifunctional, modular controllers based on open standards.

Opto 22 has been manufacturing PACs for over two decades. The standalone SNAP PAC S-series, the rack-mounted SNAP PAC R-series, and the software-based SoftPAC™ all handle a wide range of digital, analog, and serial functions for data collection, remote monitoring, process control, and discrete and hybrid manufacturing.

SNAP PACs are based on open Ethernet and Internet Protocol (IP) standards, so you can build or extend a system easily, without the expense and limitations of proprietary networks and protocols. Wired+Wireless™ models are also available.

### PAC Project Software Suite

Opto 22's PAC Project Software Suite provides full-featured, cost-effective control programming, HMI (human machine interface) development and runtime, OPC server, and database connectivity software for your SNAP PAC System.

Control programming includes both easy-to-learn flowcharts and optional scripting. Commands are in plain English; variables and I/O point names are fully descriptive.

PAC Project Basic offers control and HMI tools and is free for download on our website, [www.opto22.com](http://www.opto22.com). PAC Project

Professional, available for separate purchase, adds one SoftPAC, OptoOPCServer, OptoDataLink, options for controller redundancy or segmented networking, and support for legacy Opto 22 serial *mistic*™ I/O units.

### SNAP PAC Brains

While SNAP PAC controllers provide central control and data distribution, SNAP PAC brains provide distributed intelligence for I/O processing and communications. Brains offer analog, digital, and serial functions, including thermocouple linearization; PID loop control; and optional high-speed digital counting (up to 20 kHz), quadrature counting, TPO, and pulse generation and measurement.

### SNAP I/O

I/O provides the local connection to sensors and equipment. Opto 22 SNAP I/O offers 1 to 32 points of reliable I/O per module, depending on the type of module and your needs. Analog, digital, and serial modules are all mixed on the same mounting rack and controlled by the same processor (SNAP PAC brain or rack-mounted controller).

## Quality

Founded in 1974, Opto 22 has established a worldwide reputation for high-quality products. All are made in the U.S.A. at our manufacturing facility in Temecula, California. Because we test each product twice before it leaves our factory, rather than only testing a sample of each batch, we can guarantee most solid-state relays and optically isolated I/O modules for life.

comprehensive technical support for Opto 22 products. Our staff of support engineers represents decades of training and experience. Support is

Additional support is always available on our website: how-to videos, OptoKnowledgeBase, self-training guide, troubleshooting and user's guides, and OptoForums.

In addition, hands-on training is available for free at our

contact Opto 22 headquarters at  
or 951-695-3000, or visit our website at

